

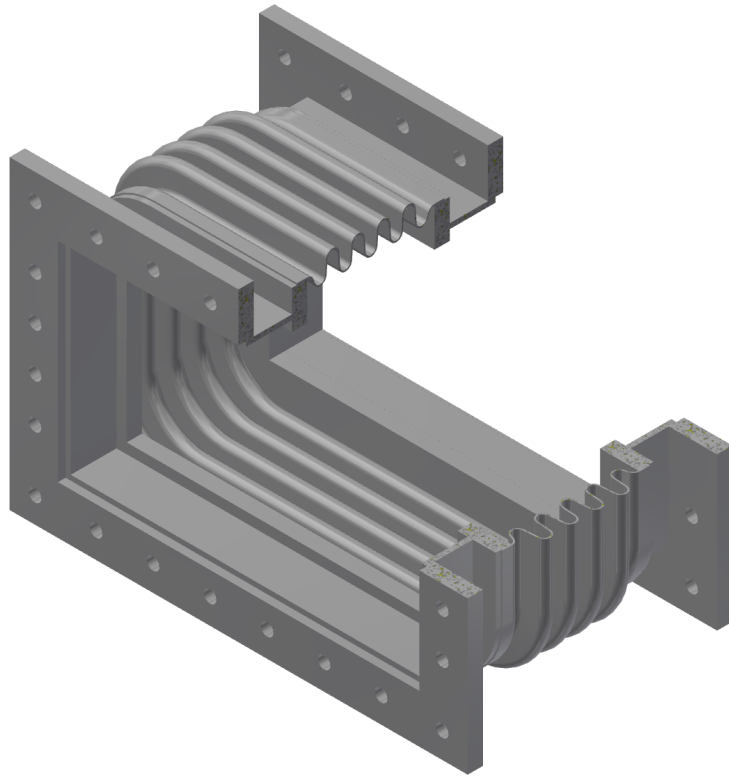

RECTANGULAR MULTILAYER EXPANSION JOINT DATASHEET



Expansion Joint Type : CB_SB_EFE_IWE_IFE_NS_LSXSS_REC

----- Rectangular Multilayer Rounded Corners Expansion Joint -----

Type suitable for High Cycles Fatigue

Rounded Corners Multilayer Design : Low CO2 Emission

NS: Nominal Size

LS: Long Side [mm]

SS: Short Side [mm]

BL: Built in Length [mm]

Dimensional Tolerances: To be specified upon request



RECTANGULAR MULTILAYER EXPANSION JOINT DATASHEET

----- Movements Suitability -----

All CUBE expansion joints are Suitable for Axial movements

SB - Single Bellows type expansion joint

Limited Suitability for Lateral movements, not recommended for large Lateral movements

Suitable for Angular movements

----- Bellows Geometry and Spring Rates-----

Bellows Geometry is strictly related to the specific design requirements

Spring Rates are strictly related to the specific bellows geometry

All bellows parameters to be specified upon request

----- Flow Conditions -----

Suitability for the flow conditions should be verified according to the specific flow data

Expansion joint without internal medium flow liner

Type Not Suitable for high flow speed of medium

----- Expansion Joint Connection End -----

All connections that are not described in CUBE types catalogue may be designed as a customized solution

Expansion joint type suitable for direct connection to the rectangular duct

Depending on the expansion joint type, connection can be weld end or flange end

CB - SB - EFE / IWE / IFE - NS - LS x SS - REC

